

Sapphire GEM™ Trap

GEM Steam Trap Technical Datasheet



ECU | Rev 8 | Jun 2021

The GEM Trap

The GEM Trap is a low maintenance steam trap with no moving parts; it will not wear and its performance is guaranteed* on saturated steam for 10 years. The unique orifice and multistaged throat technology utilizes the expansion of the flash steam created by the pressure differential across the trap to control the flow of condensate.

Operating over variable loads, the GEM Trap will suit all industrial applications. The single piece bodies are manufactured from wear and corrosion resistant grades of stainless steel.

The GEM Trap is the most energy efficient steam trap on the market and is supplied with a full sizing and commissioning service.

THE SAPPHIRE GEM TRAP

Sapphire Traps have a threaded connection and are suitable for line drainage and process applications. On all low duty applications, Sapphire Traps contain GEM's inverted cone technology to further protect the orifice from debris.

- ▶ Threaded in BSP or NPT
- ▶ Supplied with Stainless Steel spherical seat unions and strainer
- ▶ Trap body can be removed from the unions very quickly for orifice checks
- ▶ Robust reinforced mesh strainer basket with large surface area
- ▶ Strainer basket is easy to access and can be maintained inline

Suitable Applications

- ▶ Process applications
- ▶ Low condensate duty applications

Rating	PMA	TMA
DN15 / ½" to DN25 / 1"	250 psig (17.2 barg)	750°F (400°C)
DN40 / 1½" to DN50 / 2"	150 psig (10.3 barg)	750°F (400°C)

Ancillary Parts

- ▶ Insulation Jacket
- ▶ Optional drainage valve

Available Spares

- ▶ Quality SS reinforced graphite gaskets
- ▶ Robust SS reinforced strainer basket

Sizes & Connection Types Available

	BSP / BSPT / NPT
DN15 / ½"	✓
DN20 / ¾"	✓
DN25 / 1"	✓
DN40 / 1½"	✓
DN50 / 2"	✓



Key GEM Trap Benefits

Quality, Efficiency, Reliability and Service

Permanent Energy Savings

- ▶ Typical payback < 2 years
- ▶ Inherently more efficient than mechanical steam traps

10 Year Performance Guarantee*

- ▶ No moving parts to wear or fail
- ▶ No inserts – no leak path

Reduced Maintenance

- ▶ No on-going trap surveys
- ▶ Minimal annual maintenance

Improved Process Control

- ▶ No pressurization of condensate return system
- ▶ Elimination of steam trap related waterhammer

Performs Across Industrial Variable Loads

- ▶ Each trap supplied with full sizing and commissioning service

* Reduced guarantee offered for superheated steam



Sapphire GEM™ Trap

GEM Steam Trap Technical Datasheet



ECU | Rev 8 | Jun 2021

Product Diagram

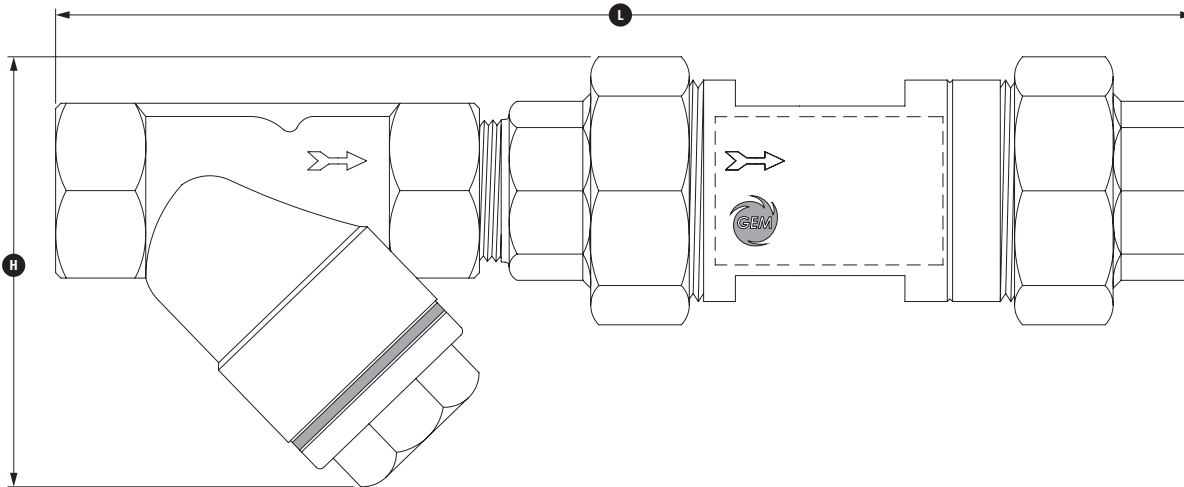

Dimensions & Weights

	S15 (DN15 / 1/2")	S20 (DN20 / 3/4")	S25 (DN25 / 1")	S40 (DN40 / 1 1/2")	S50 (DN50 / 2")
Height (H)	2 3/4"	3 5/32"	3 15/16"	4 41/64"	5 33/64"
Length (L)	7 3/32"	8 5/16"	9 41/64"	12 3/64"	12 63/64"
Weight	2.43 lbs	3.53 lbs	5.51 lbs	11.02 lbs	19.84 lbs

Materials

Part	Material
Trap Body	BS EN 10088-3 1.4305 / ASTM A582 303
Unions	Cast Stainless Steel ASTM A351 CF8M
Strainer Body	Cast Stainless Steel ASTM A351 CF8M
Strainer Cap	Cast Stainless Steel ASTM A351 CF8M
Strainer Basket DN15 to DN25	Reinforced 316 Stainless Steel 40mesh (425µm)
Strainer Basket DN40 & DN50	Reinforced 316 Stainless Steel 40mesh (425µm) or 5/64" perforated plate
Gasket DN15 to DN25	Metakamm® 316 Stainless Steel Core / Graphite-faced
Gasket DN40 & DN50	FEP O-Ring

- ▶ Full product traceability is part of our Quality Assurance procedure
- ▶ Type 3.1 material certification to BS EN 10204:2004
- ▶ Thermal Energy reserve the right to amend material specification

All certification/inspection requirements must be stated at time of order placement.

FOR FURTHER INFORMATION

For further information on the full GEM™ Trap range contact us at technical@thermalenergy.com or visit www.thermalenergy.com



An Innovative Technology Company Providing Custom Energy and Emission Reduction Solutions
technical@thermalenergy.com / www.thermalenergy.com